

Fully automated production line with which new tastes and shapes of product are created by compounding more than two different food materials.

MULTI CO-EXTRUDER

Multiple co-extruding and molding system UX108 · UX110 · UX112

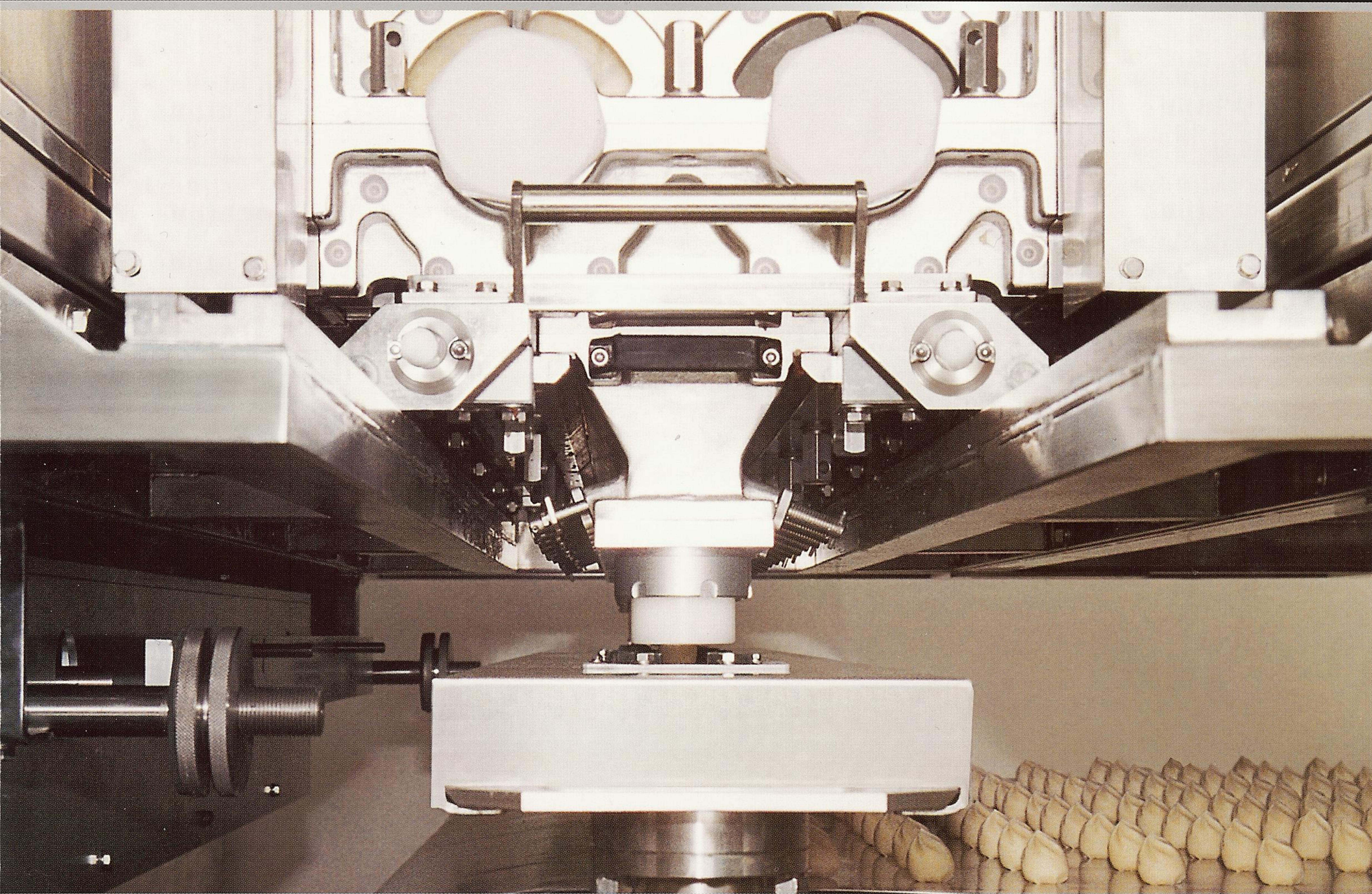

Spherical forming with "High Speed Encruster" (Cookies with filling)

Multi Co-Extruder with maximum of 14 nozzles and various secondary forming devices realizes high productivity and wide variety of shaping capabilities.

RHEON[®]

Multi Co-Extruder encrusts various products smoothly by using "Rheon High Speed Encruster". Various kinds of encrusted products can be created with the optional devices.

Multi Co-Extruder can manage from 6 to 14 row production and produce up to 100,800 pieces of products per hour (for 14 rows). Optional forming devices are available to create unique and original products by combining various kinds of food materials. Superior products can be produced with accurate weighing and ratio adjustment (for inner and outer materials).

● "High Speed Encruster" (Optional Device)

- The production capacity is 120 pieces of products per minute in each row.
- Even if inner material is soft such as jam or cream, it can be encrusted completely. It is also possible to mix chocolate chips or nuts into inner or outer material.

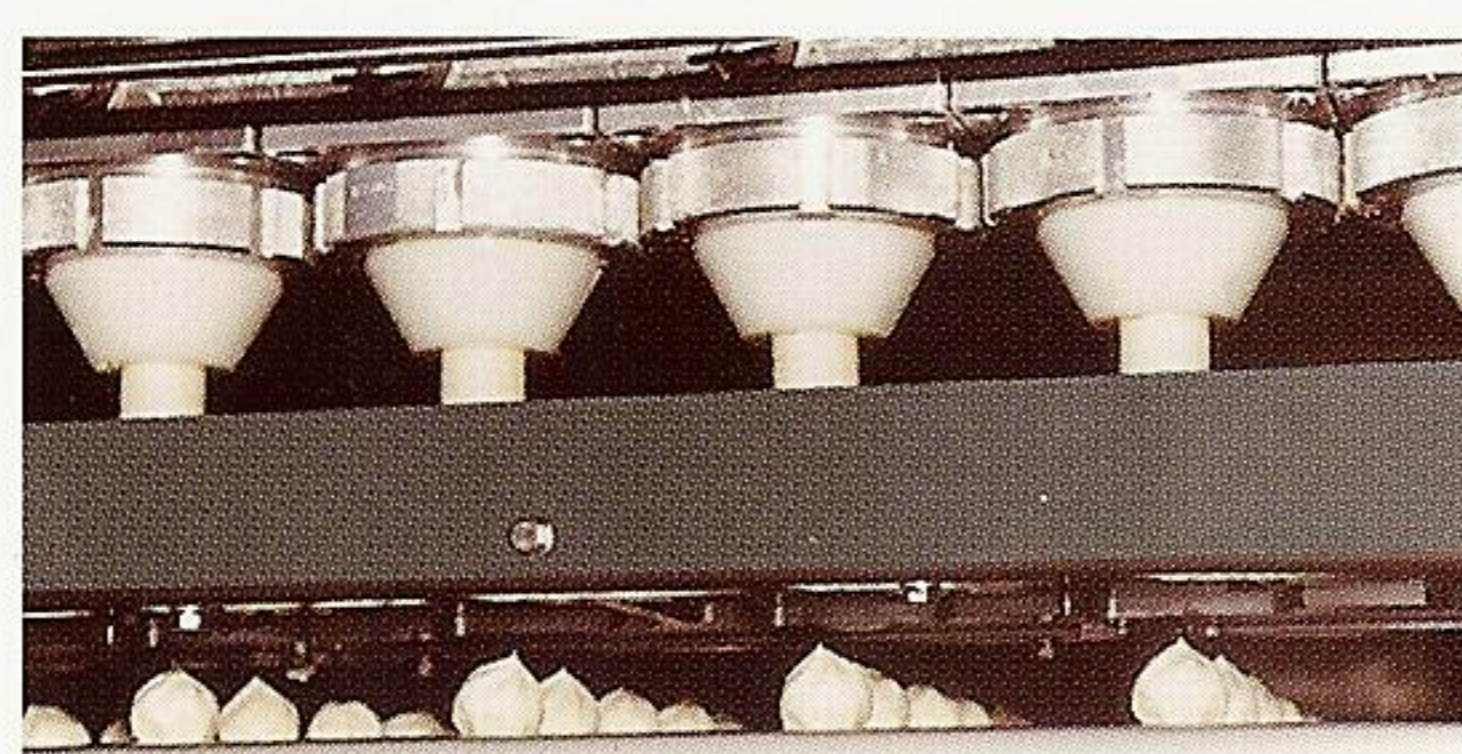

● Stable production based on highly accurate weight control by computer.

Product volume, encrusting ratio, and product length can be changed as desired. Accurate weighing by computer can manage a stable production.

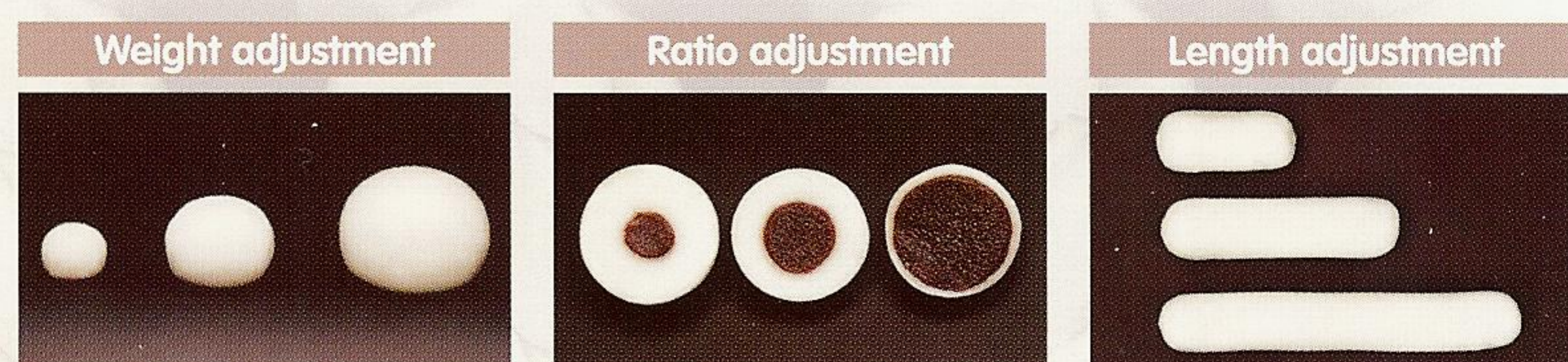

Application of products with optional devices as secondary molding

Multi Co-Extruder can automatically run "High Speed Encruster" and "Wire Cutter"

Spherical forming with "High Speed Encruster".

Forms encrusted spherical products into a required shape with "Press Roller" and "Lattice Roller".

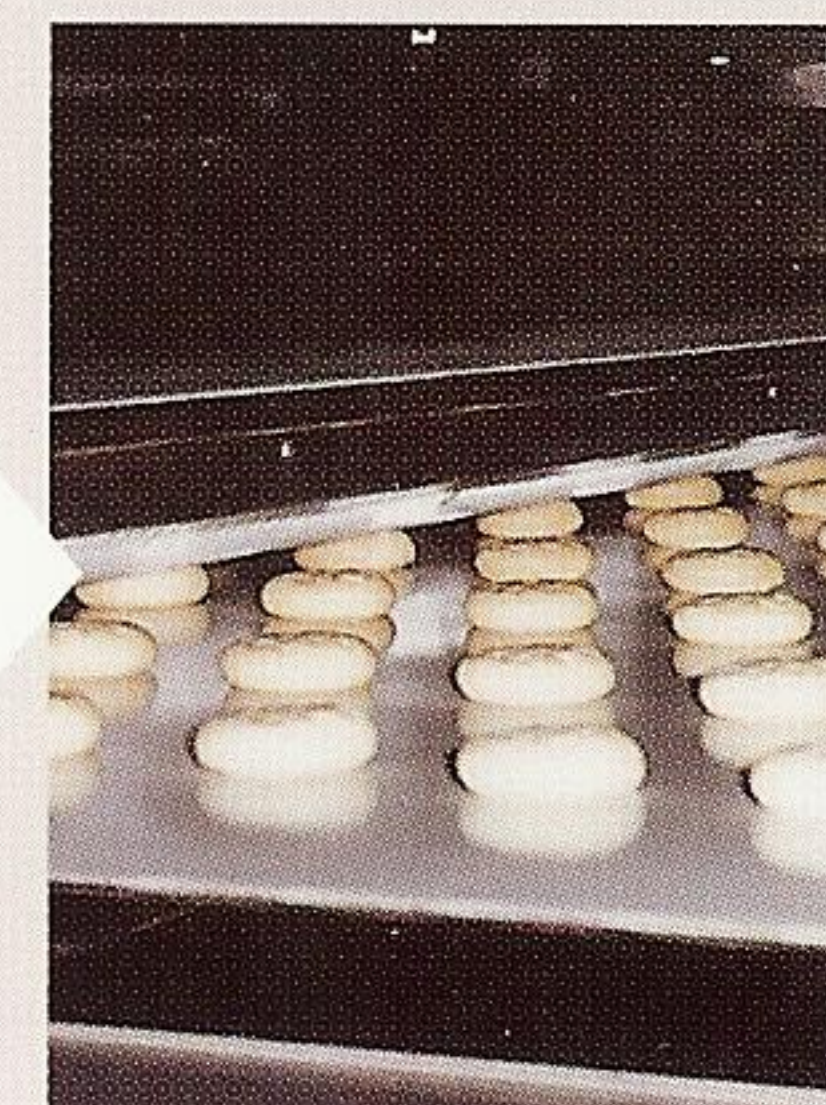
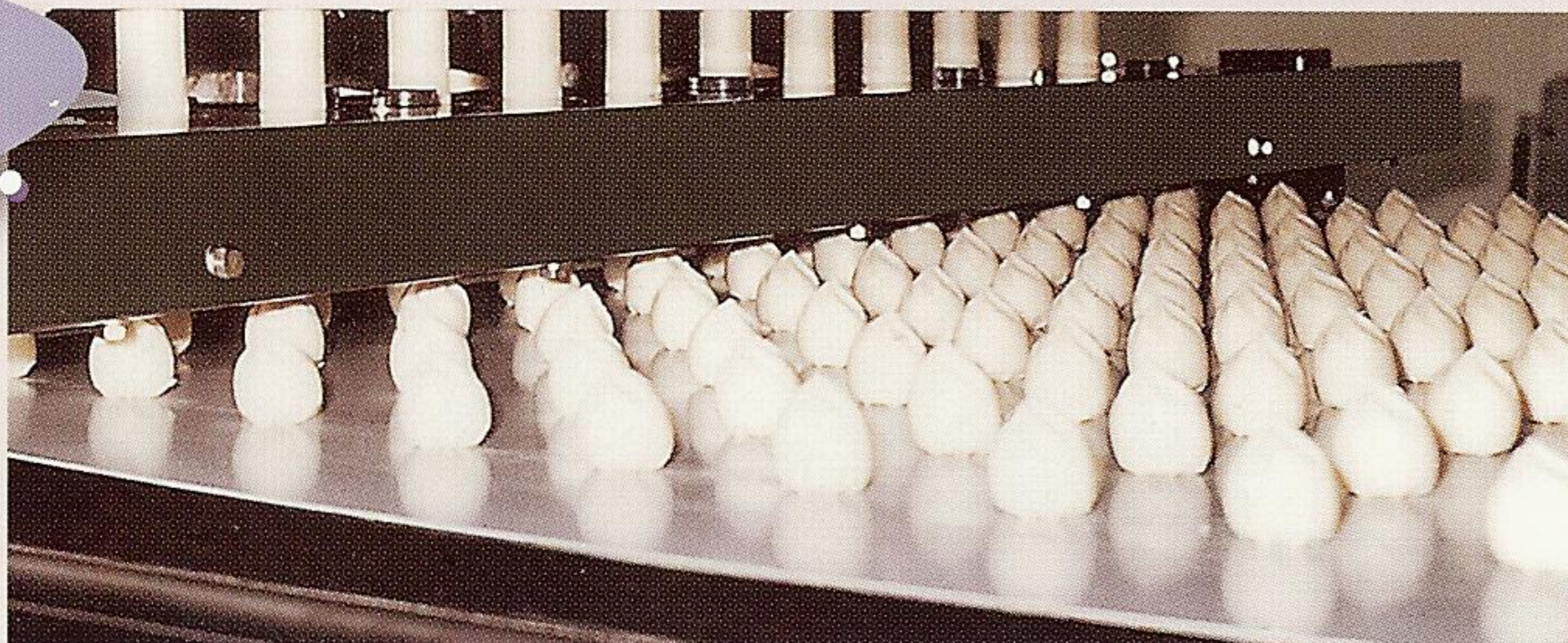

"Wire Cutter Unit".

Cut extruded products with required thickness.



Shaping with "Fruit Bar Unit".

Forms continuously extruded rope into a required shape with "Blade Wheel" and "Guillotine Cutter".

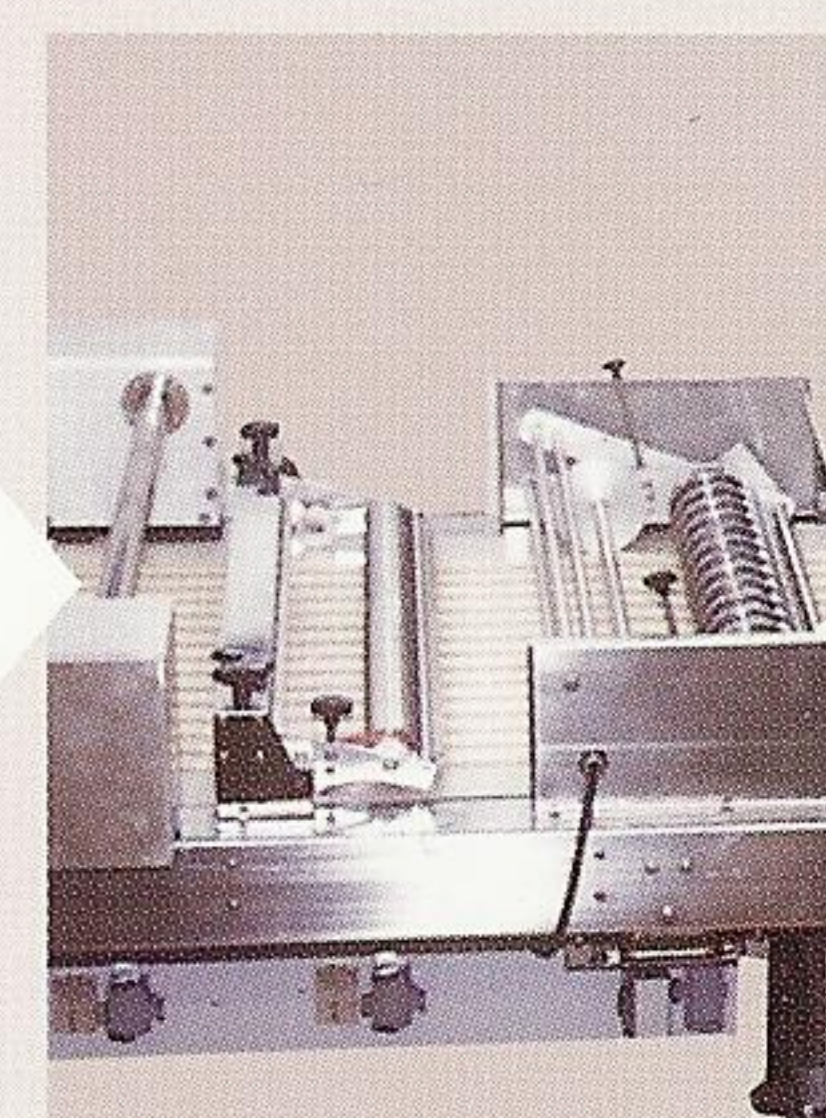
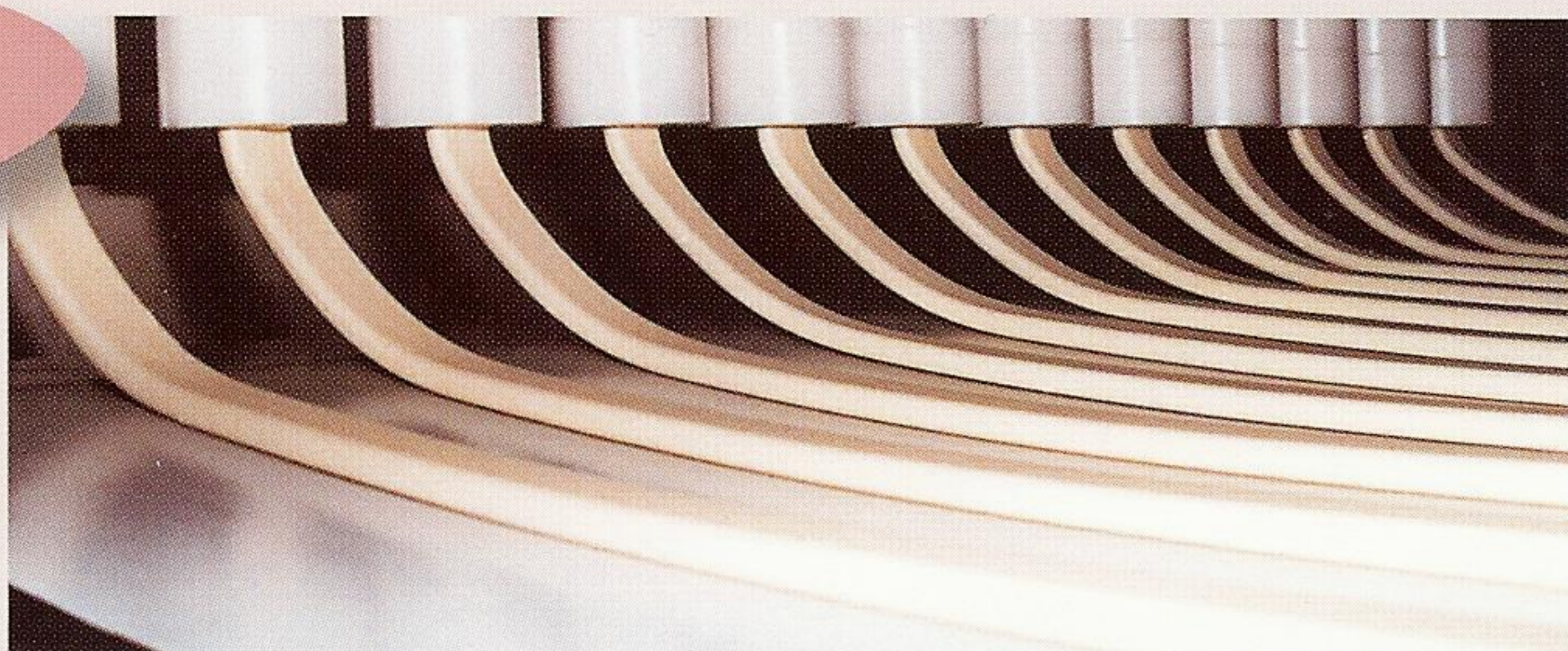

"Cookie Slicer".

After cylindrical extruding, products are frozen and cut with "Cookie Slicer" (Another line).

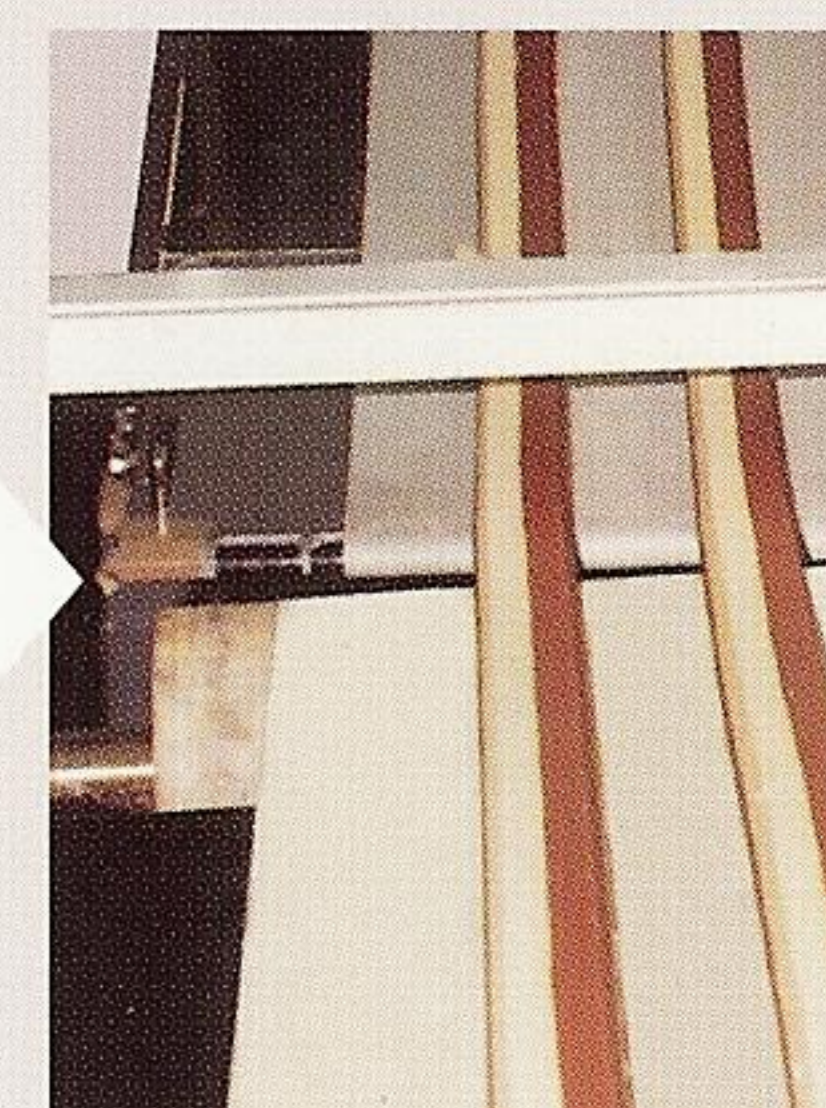
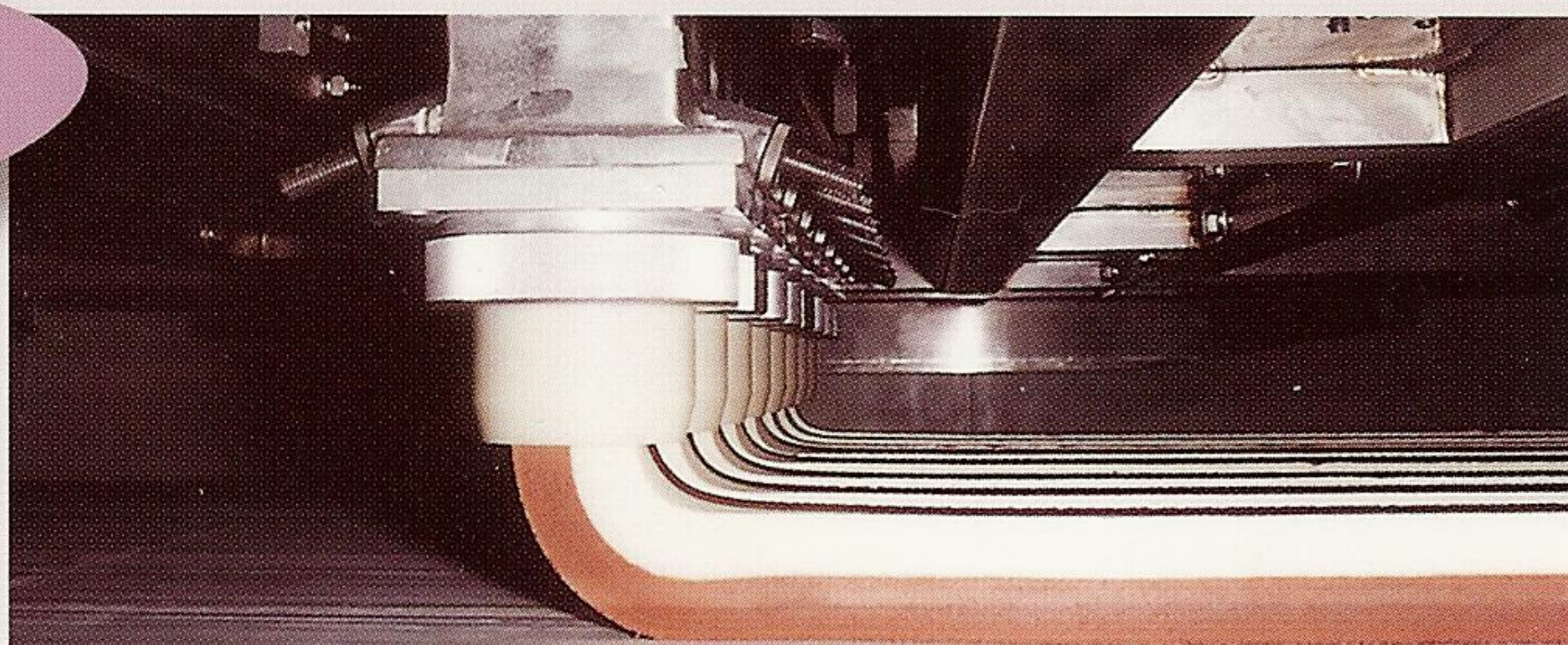

Bar shape forming with "High Speed Encruster".

Encrusts bar shape products into required length.

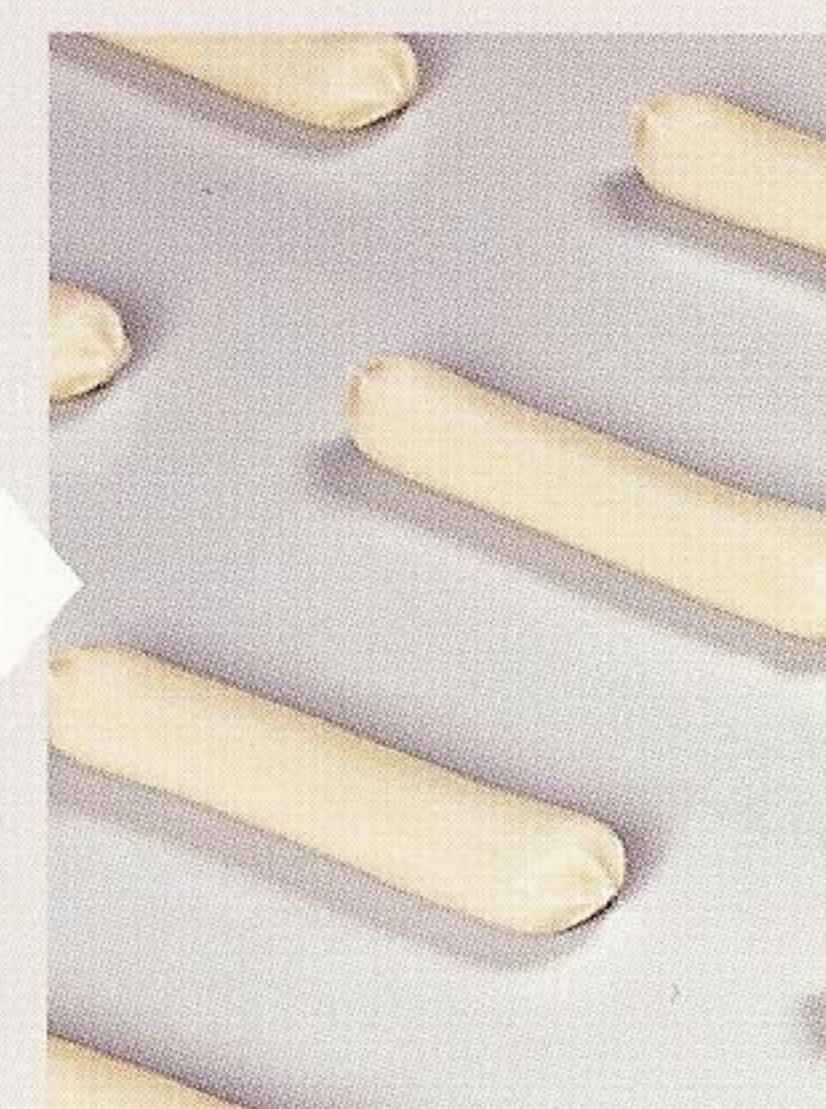
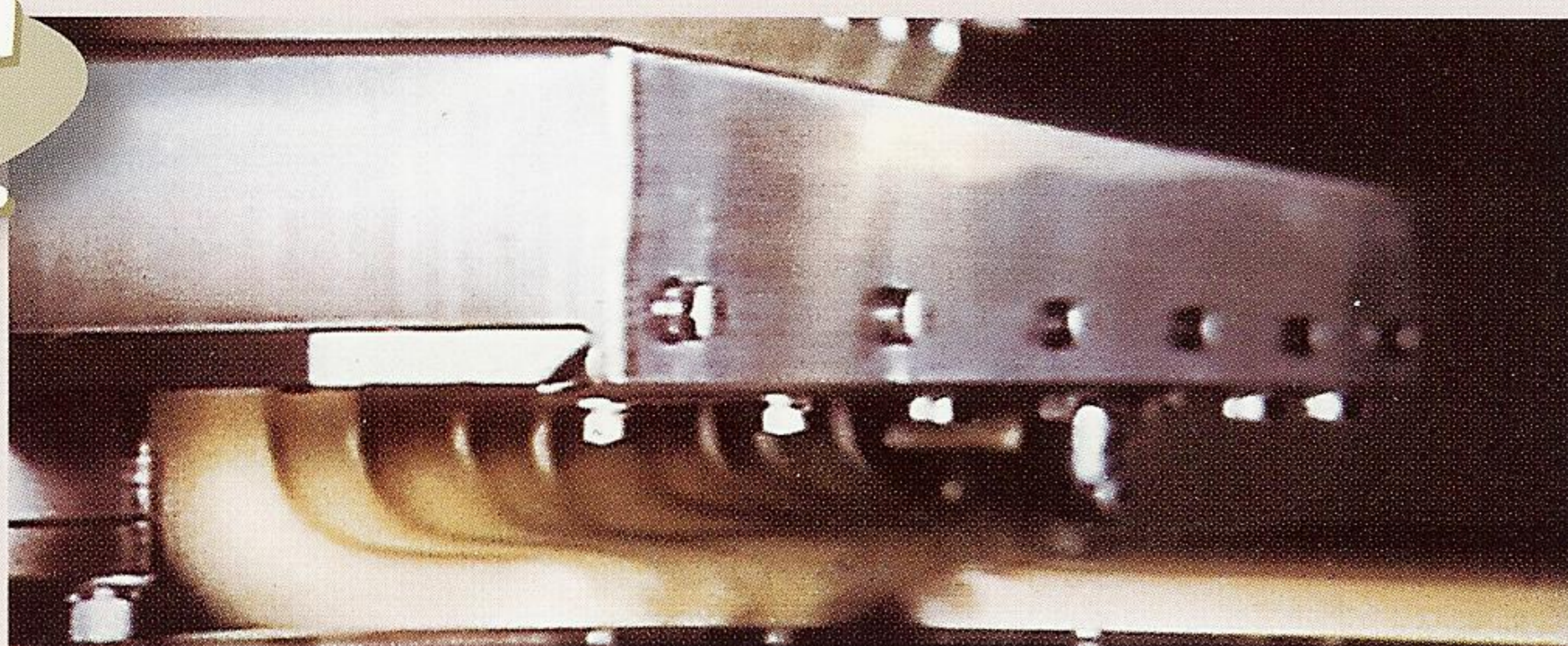

Forming with "Twist Nozzle".

After twisting, cut the products into required length.

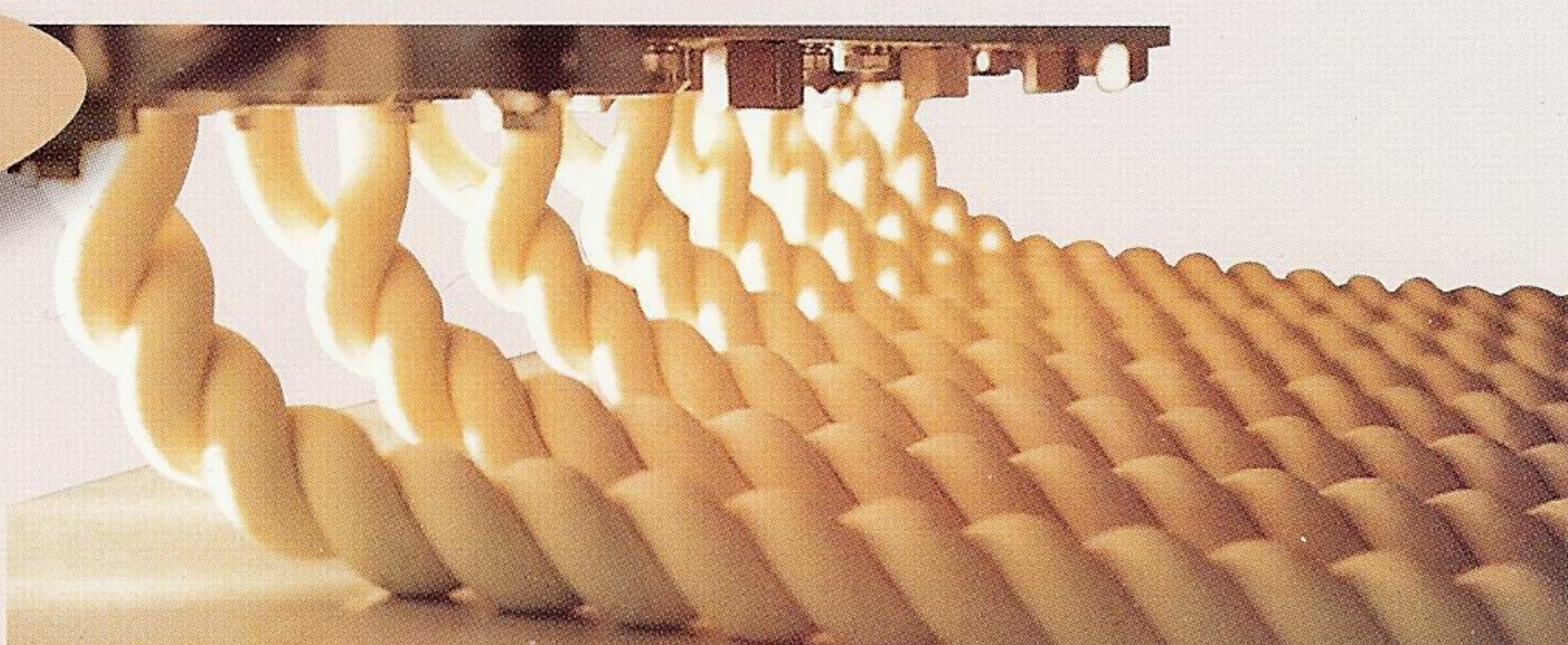

※ Twist Nozzle available for Model UX108 UX110.

manage attractive shaping with a combination of various secondary forming devices. "Letter Unit" are equipped on "Multi Co-Extruder" main body. Other optional devices are placed on the conveyor.

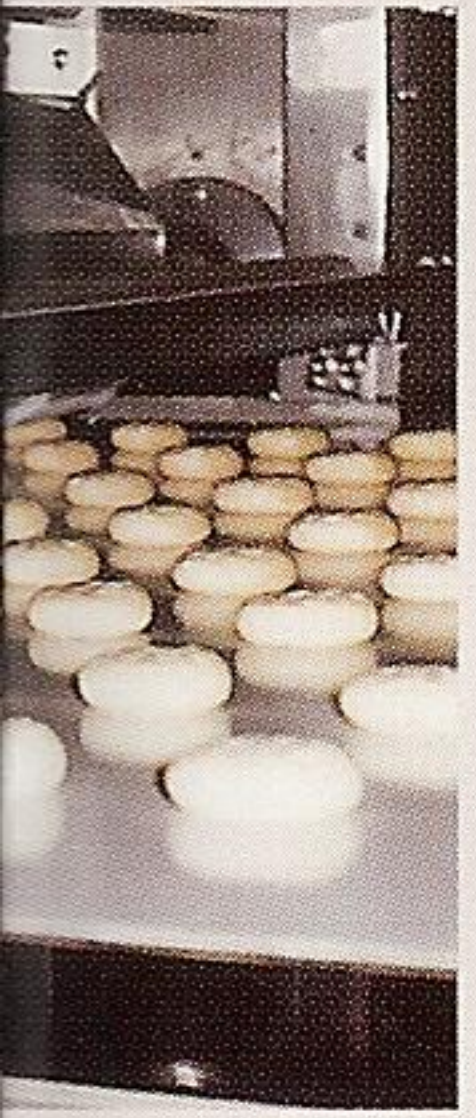

Lattice Roller"

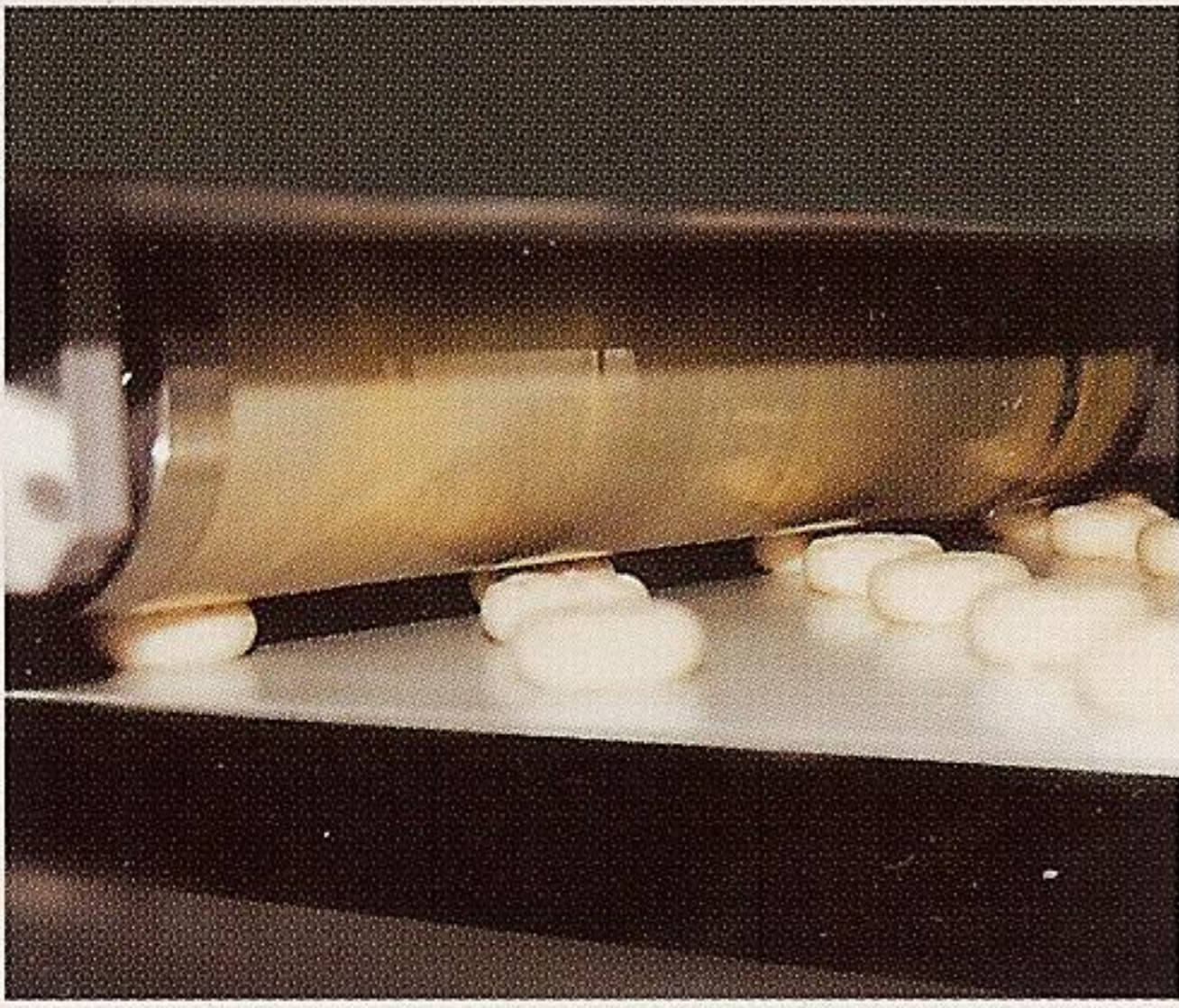

"Egg Glazer"



Soft Filling Cookie



Double Filling Cookie (By use of "Double Filling Feeder")



Mosaic Cookie



White Chocolate Cookie



"Blade Wheel" and "Guillotine Cutter"



Cookie Bar With Jam Filling.



Fruit Bar



Ice Box Cookie



Flower Cookie (By use of "Double Filling Feeder")



Bar Shape Cookie With Filling (Long).



Bar Shape Cookie With Filling (Short).



Twisted Cookie With Filling



Twist Cookie (By use of "Double Filling Feeder")

The design and size of products are freely choosable.



Soft Filling Cookie



Cereal Cookie



Chocolate Chip Cookie



Macaroon With Orange Jam Filling



Ice Box Cookie



Cereal Cookie Bar



Fruit Basket



Rum Kugeln

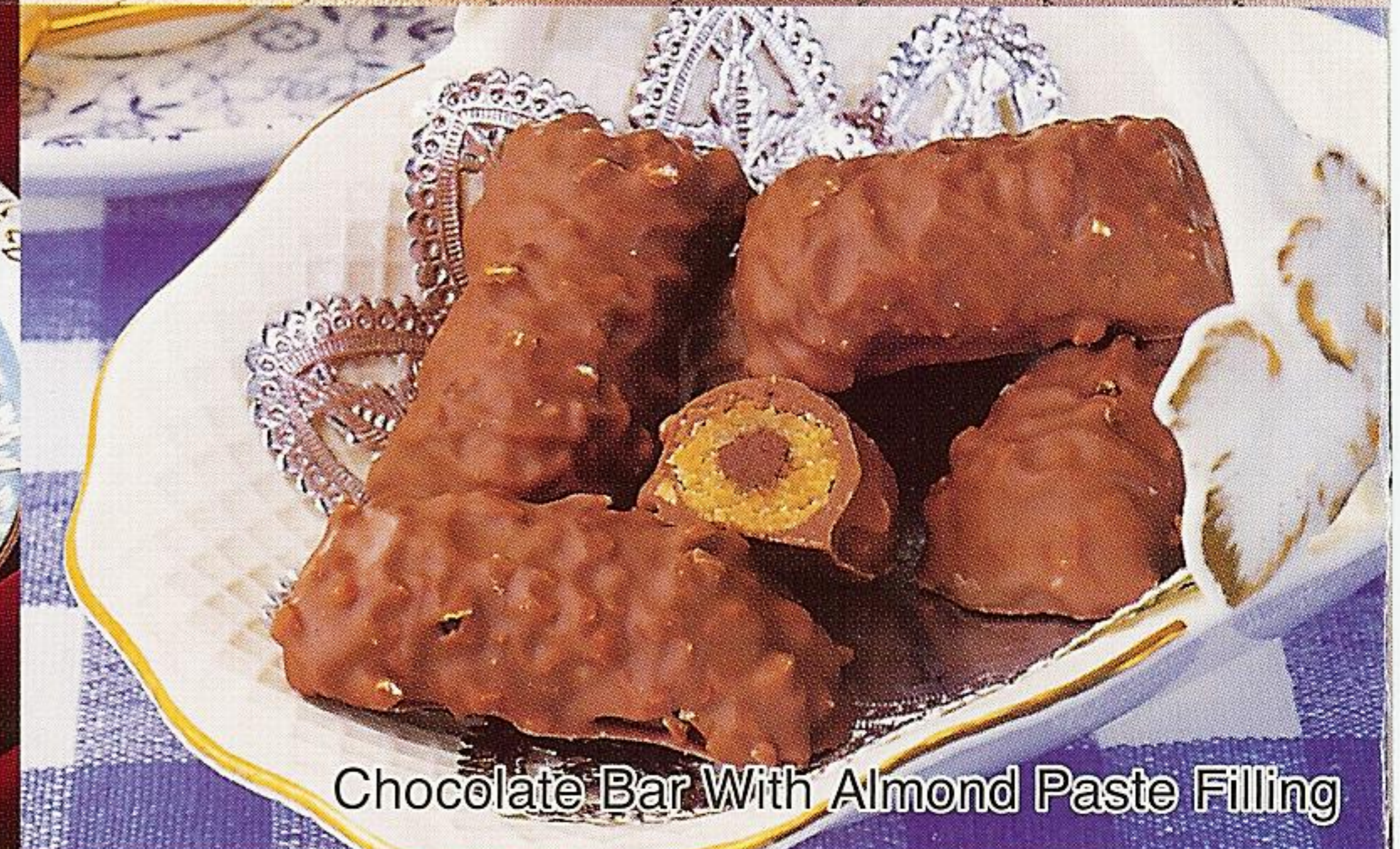

Chocolate Bar With Almond Paste Filling



Cookie Chou



Open-Top Cookie



Chocolate-Tortchen

"Double Filling Feeder" can produce high value added products with two different kinds of filling.



Marguerite Cookie



Marble Praline

Washable type is available for savory foods production.



Gnocchi



Fish Cake

Multi Co-Extruder is easily movable.

The extruder body is mounted on rails to allow easy off-setting from the line for preparation or maintenance.

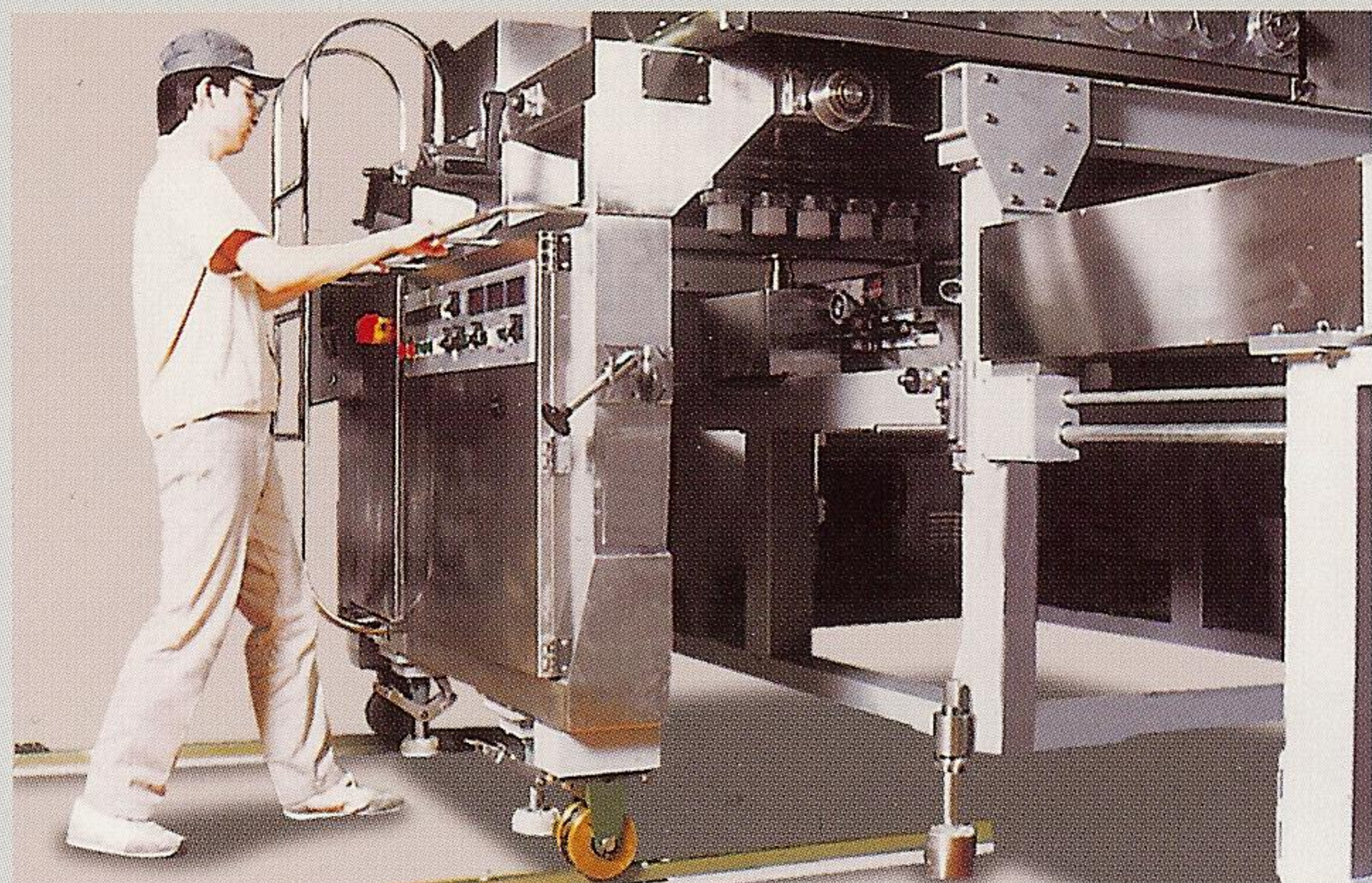

Compound Nozzle unit is easily detachable.

The cartridge type compound nozzle is easily slid out for cleaning and changing for nozzles.



Tandem use of Multi Co-Extruder allows higher production capacity.

Put two Multi Co-Extruders together so as to get double production capacity even in a limited space.

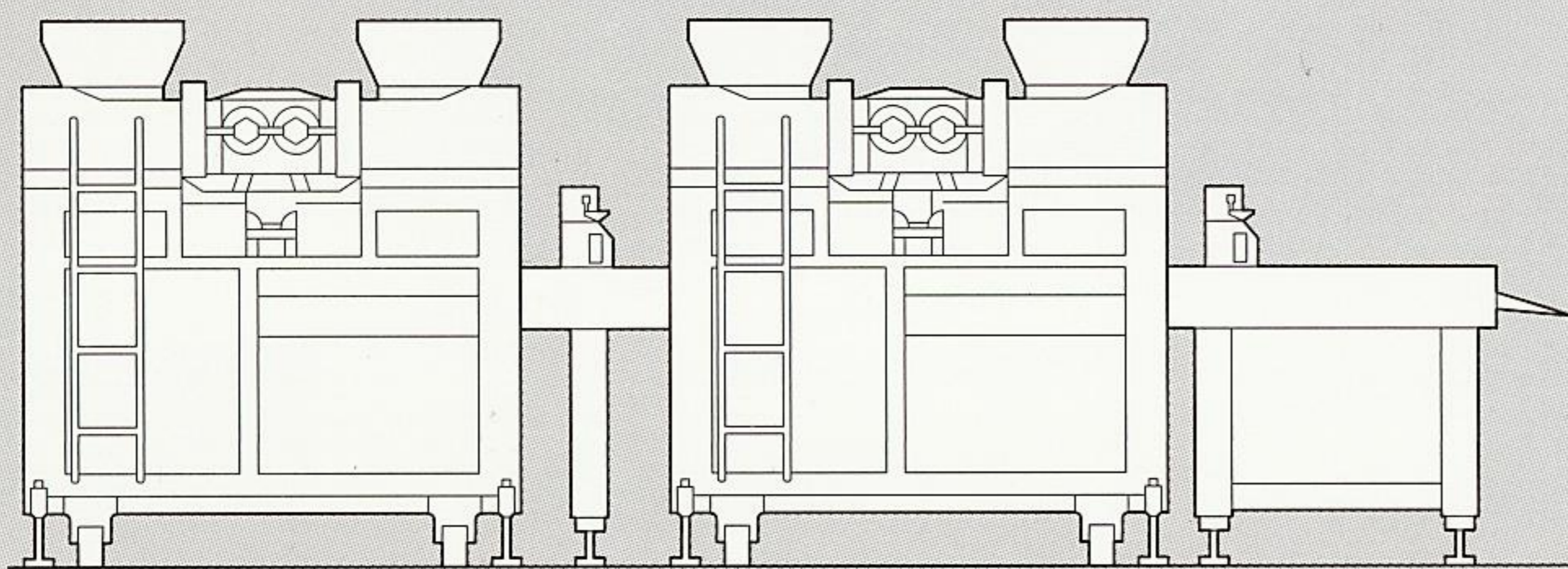

Dimension / Specification / Capacity

(An example of a cookie production line.)

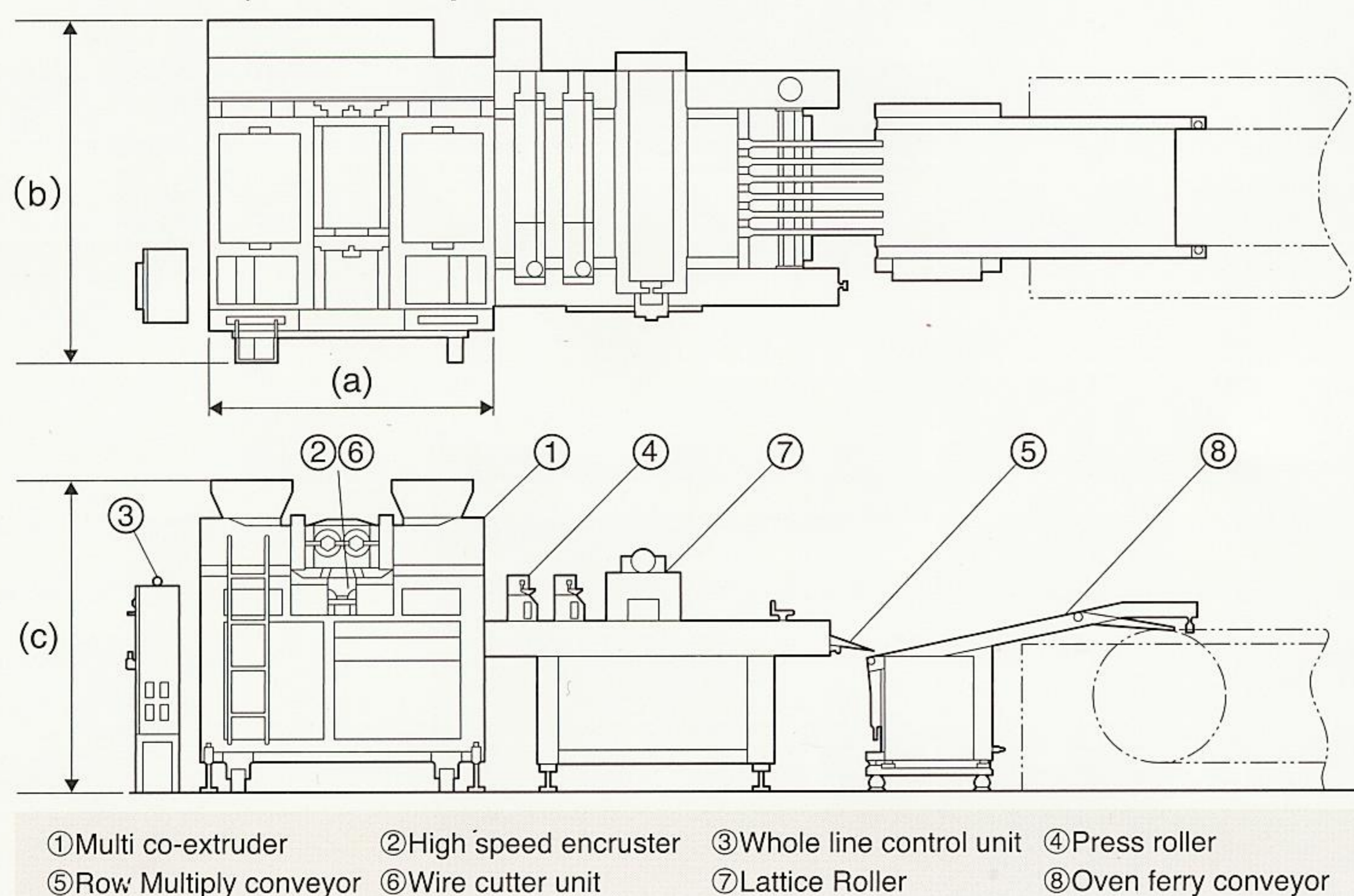

Model Code	UX108		UX110		UX112	
Applicable band oven width	800mm		1000mm		1200mm	
Total Length (a)	1940mm					
Total Width (b)	2445mm		2685mm		2925mm	
Total Height (c)	2110mm					
Extruding Capacity(total)	1500kg/h		2000kg/h		2500kg/h	
Number of extrusion nozzle	6rows	9rows	8rows	12rows	10rows	14rows
Output	43200pc/h	64800pc/h	57600pc/h	86400pc/h	72000pc/h	100800pc/h
Electrical Capacity	4.5kW					
Air	0.4MPa, 1Nℓ / min.					
Hopper Capacity	150ℓ		200ℓ		250ℓ	

The specifications are subject to change without notice and without obligation. All rights reserved. Reproduction, adaptation or translation without prior written permission is prohibited.

RHEON®

RHEON AUTOMATIC MACHINERY CO., LTD.

Head Office: 2-3 Nozawa-machi, Utsunomiya 320-0071, Japan
 Phone: 028-665-1111 Fax: 028-666-1013 E-mail: info@rheon.com

RHEON U.S.A.

9490 Toledo Way, Irvine, CA 92618, U.S.A.
 Phone: 949-768-1900 Fax: 949-855-1991 E-mail: us.info@rheon.com

RHEON U.S.A. NJ BRANCH

375 North Street, Unit K, Teterboro, NJ 07608, U.S.A.
 Phone: 201-487-0600 Fax: 201-487-0610 E-mail: us.east@rheon.com

URL: <http://www.rheon.com>

RHEON AUTOMATIC MACHINERY GmbH

Tiefenbroicher Weg 30, 40472 Düsseldorf, F.R.Germany
 Phone: 0211-471950 Fax: 0211-424129 E-mail: de.info@rheon.com

RHEON AUTOMATIC MACHINERY ASIA PACIFIC CO., LTD.

3F., No.180, Xinhua 2nd Rd., Neihu District, Taipei City 114, Taiwan (R.O.C.)
 Phone: 02-8791-2227 Fax: 02-8791-1295 E-mail: tw.info@rheon.com

No. S-FNUX-001-3C

©RHEON AUTOMATIC MACHINERY 2001

Printed in Japan. 08032000Y